

Blackfin Stampet Board and TCP/IP Engine

Background

Bolton Engineering was working on several Blackfin projects and needed a miniature development board that could be used to jump-start software development. Two of the projects needed to run Linux, and also required significant programmable logic content. Using the Analog Devices [Blackfin Stamp](#) board as a starting point, Bolton Engineering designed the Blackfin Stampet.

System Overview

The Blackfin Stampet is constructed around the Analog Devices BF531/2 [Blackfin](#) processor. It stores UBOOT, Linux, and simple application programs in its on-board Flash memory, and connects to an external FTP server to access larger application programs and datasets. It executes its programs from on-board SDRAM running at the maximum Blackfin bus speed of 125MHz. It's on-board 6000 Logic Equivalent (LE) sized Programmable Logic Device (PLD) may be configured to implement a variety of custom peripherals or interfaces. With careful planning, Bolton Engineering was able to fit the Blackfin Stampet and Ethernet interface onto a 2.25" x 2.90" board of only 6-layers. An enhanced version of this board with more Flash memory is in

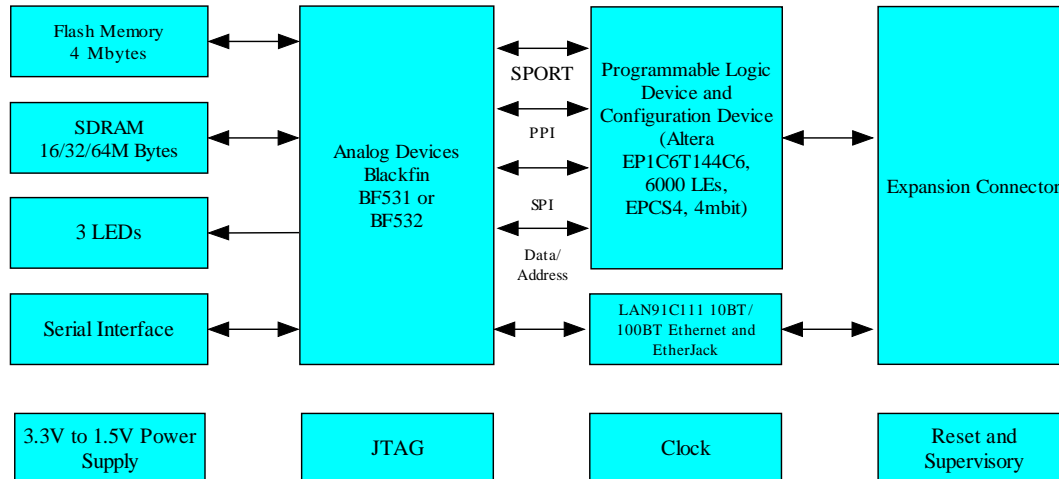

development.

TCP/IP Engine

One of the first applications for the Stampet was a configurable TCP/IP Engine to dump large amounts of data from an experimental Software Radio System. The Stampet took in 16-bit data at high speed and dumped it out to an FTP server. The PLD implemented a straightforward 16-bit interface into the Blackfin memory via the Blackfin's Programmable Parallel Interface (PPI). A simple handshake protocol controlled data flow. All software was written as an application-level program under Linux. The system was able to sustain an over 30MBPS data rate through a dedicated Ethernet link to an FTP server.

Project Scope

Bolton Engineering wrote the specification, designed the schematics, designed the 6-layer circuit board, bought up UBOOT and Linux, wrote driver application in 'C', debugged the system, and delivered over fifty boards to several clients.